

SP6DSSTB7

33.25" x 23.75" x 23.58" (H x W x D)

Commercially approved built-in three-drawer stainless steel refrigerator with auto defrost

Highlights:

- Commercially approved for use in foodservice establishments
- Perfectly sized to fit under counters and in tight 24 inch spaces
- Three slide drawers with elegant towel bar handles
- Stainless steel construction adds durable luxury to any setting



Built-in capable	Make the best use of space by installing your appliance under the counter and flush with other cabinets
Fully finished cabinet	Allows the refrigerator to be used freestanding
Stainless steel construction	Enhance any room with durable luxury
Commercially approved	ETL-S Approved to ANSI-NSF Standard 7
Slim undercounter dimensions	Less than 24 inches wide to fit tight spaces
Height adjustable	Four large leveling legs let you adjust unit height for the best undercounter fit
Three slide-out drawers	Easy gliding drawers offer more storage options
Automatic defrost	Reduced maintenance with auto defrost system
Professional towel bar handles	Curved stainless steel handles add function and elegance, providing more room for a comfortable grip
Spring assisted rollers	Enjoy the gentle gliding motion that helps you open the drawer and keep it firmly closed

Specifications:

Height	33.25 up to 34.5"
Width	23.75"
Depth	23.58"
Capacity	5.4 cu.ft.
Ext Depth with Handle	24.63"
Interior Height 1	27.75"
Interior Width 1	20.0"
Interior Depth 1	17.5"
Comp Step Height	7.0"
Comp Step Width	20.0"
Comp Step Depth	6.0"
Height Adjustable	true
Shipping Weight	140.0 lbs.
Energy Usage/Year	423.0 kWh/year
Canadian Electrical Safety	ULC
Amps	1.3
US Electrical Safety	UL
Drawers	true
Drawer Quantity	3
Defrost Type	Automatic
Depth with door at 90°	40.5"
Fan Type	Interior and Exterior
Thermostat Type	Dial
Level Legs Quantity	4
Freon Oz	1.8
Low Side PSI	70.0
High Side PSI	285.0
Refrigerant Type	R134a
Parts/Labor Warranty	1 Year
Compressor Warranty	5 Years
Sanitation	ETL-S

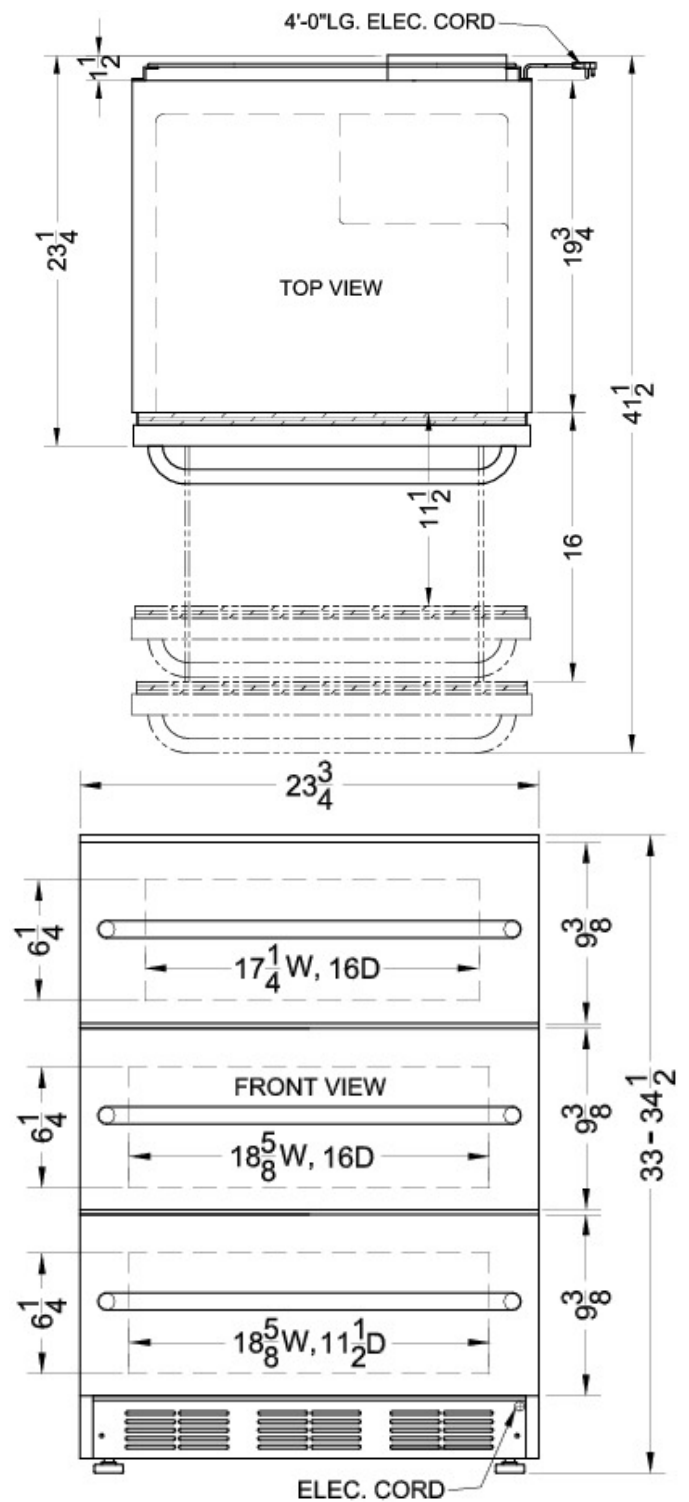

Summit Appliance Division, Felix Storch, Inc.
 770 Garrison Ave • Bronx, NY 10474
 Phone: 718-893-3900 • Fax: 718-842-3093
 Email: info@summitappliance.com