



In Wall 3/4" Stop Valve - PL2000W

Before Your Installation

- Read all instructions carefully. Before Beginning
- Assemble all tools.
- Turn off main water supply before beginning installation
- HB recommends that when cleaning your HB product only use soap and warm water.
- The use of any chemical substance will void finish warranty.
- All HB products are design and manufactured to provide the highest quality performance provided they are installed and used properly.

Installing the HB in wall 3/4" stop valve

- The plumbing lines used in installation may be copper pipes
- When soldering copper connections DO NOT overheat the valve body. If this is foreseen as a potential problem be sure to remove cartridge components before applying heat.
- Look carefully at the diagrams provided on the reverse side of the installation sheet.
- Be sure to install the valve such that the arrow marking on the valve is consistent with the direction of water flow.
- When installing the trim, the stem and thread lengths may have to be cut to specific dimensions to fit certain styles of trims. Trim installation is shown on the reverse side. To show how to install various HB trims that require different stem lengths.



Tools You Will Need For Installation



Silicon Caulking

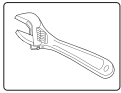

Adjustable Wrench

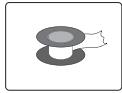

Seal Tape

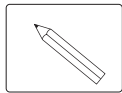

Pen

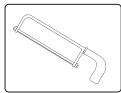

Metal Cutting Tool

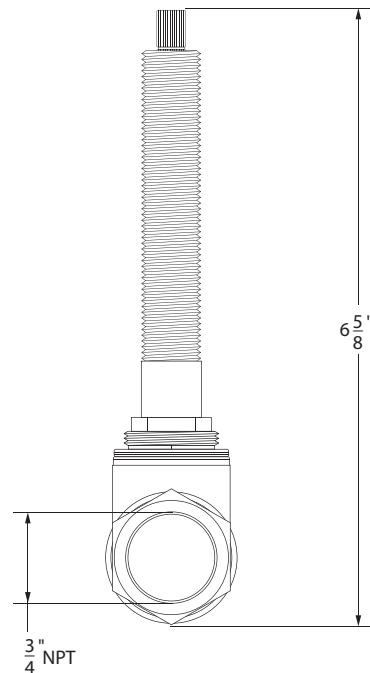
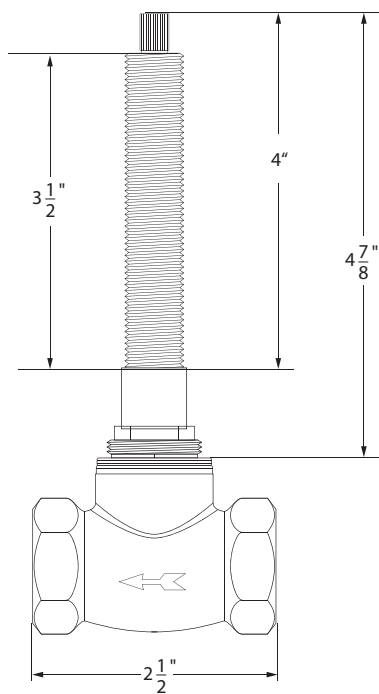

Important

Valve stem & thread will have to be cut differently to fit various trims. Make sure that no part of the valve is altered until trim is in hand ready to install. HB will not assume responsibility for installation negligence.

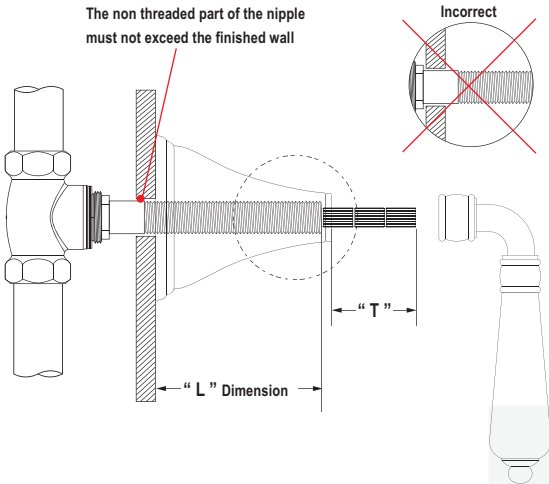

Before Installing Handle Trim

1. "L" dimension - The "L" dimension is the length that the all thread (9/16-20) nipple should be cut to for applicable trim installation. To find the "L" dimension, see step 1 of the trim installation process.

2. "T" dimension - The "T" dimension is the length of the stem that should protrude from the escutcheon base after the nipple is marked, cut and installed back on the valve.

Handle Tip	" T " DIMENSION
PL *	1/2"
ML *	1/2"
BX *	3/4"
AL *	3/4"
DL *	1/2"
CL *	7/8"
BJ *	9/10"
JL *	9/10"
BZL (Bellezza Lever)	see step 4
BZX (Bellezza Cross)	see step 4
ASL (Atlantis Lever)	see step 4
CCP (Chameleon w/ Metal)	see step 4
CNK (Chameleon w/ Metal)	see step 4
CGD (Chameleon w/ Ceramic)	see step 4
CGN (Chameleon w/ Ceramic)	see step 4
WBL (Wyndamere Lever)	see step 4

* Handle tips indicated can be used with various different handle bases all handle bases have a different height dimension. Thus, the "T" length must be measured from the end of the escutcheon after installation onto the threaded nipple.

1 Finding the "L" Dimension

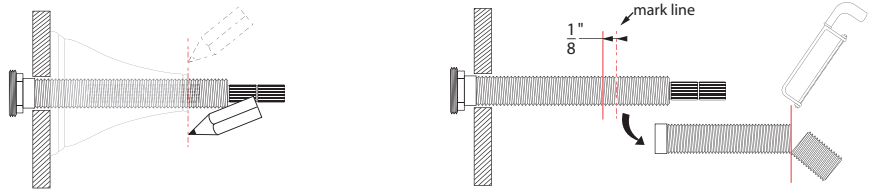

To find the "L" dimension after the rough-in is installed and the finished wall is completed, first install the handle escutcheon and ring (if applicable). Mark the threaded nipple where the escutcheon ends. Remove the nipple by unscrewing and then cut the nipple 1/8" below the marking to ensure that the handle tip will fit flush with the escutcheon. Once the nipple is cut to the proper length, reinstall onto the cartridge stem, and prepare to measure the "T" dimension for the stem length.

2 Finding the "T" Dimension

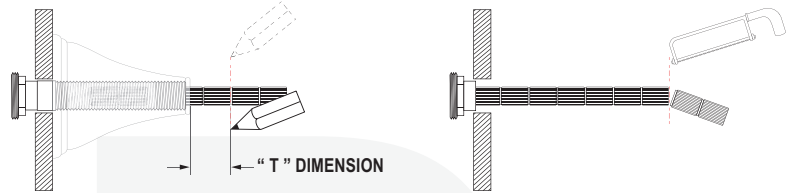

To find the "T" dimension, first reinstall the escutcheon and base ring after the threaded nipple has been cut to the correct length. Make sure that none of the threaded nipple is protruding from the escutcheon. Next, cut the broach to the specific "T" dimension for the handle style that is applied. Cut the broach stem at the notch area if possible, if not then some filing of the end of the stem may be needed to fit the handle tip on the stem.

3

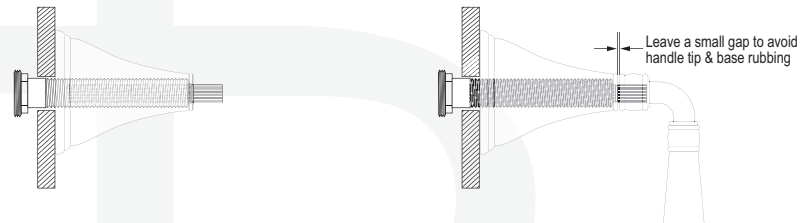

Finally, after the threaded nipple and the stem are cut to the proper dimensions for the trim to be installed, you can install the handle trim parts. First, place the ring or flange on and screw the handle escutcheon onto the threaded nipple until tight. HB advises using silicone caulking where the wall and the escutcheon meet. Next, install the handle tip by sliding the handle tip onto the stem and securing with the set screw (some handles may use a top down screw to install) Make sure the handle tip is pointed down in the off position.

4 Special Adaptor Install for Bellezza / Chameleon / Atlantis

BELLEZZA

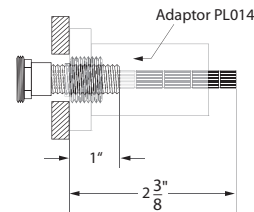

ATLANTIS

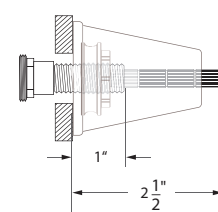

Chameleon

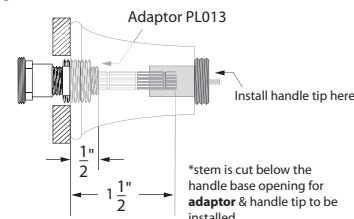

Wyndamere

