



JEWEL - Wide Spread Faucet

JWWSxxHML/ JWWSxxHSC/ JWWSxxJML/ JWWSxxJSC

Description

- 8" wide spread faucet
- Ceramic disc cartridges
- Solid brass construction
- 1/2" S.S. braided hose
- Brass popup

Standards

- ASME A112.18.1 Compliant
- Listed IAPMO / cUPC
- ADA Accessibility Guidelines for Buildings and Facilities - 4.27.4 Controls and Mechanisms (lever handle only)
- NSF - 61-9 tested and approved
- CSA B125.1 Compliant and listed
- AB 1953 compliant



Colors / FinishES

- | | |
|---------------------|----------------------------|
| 01 - Chrome | 29 - Polished Nickel |
| 12 - Satin Nickel | 70 - Polished Brass (PVD) |
| 20 - Antique Bronze | 71 - Polished Nickel (PVD) |
| 21 - Antique Brass | 72 - Satin Nickel (PVD) |
| 22 - Antique nickel | 73 - Satin Brass (PVD) |
| 23 - Antique Copper | |
| 24 - Satin Copper | |
| 27 - Matte Nickel | |
| 28 - ORB | |

Please add finish code when placing order for parts with using following finish code table. For example J handle in Chrome will be BJ-01, BJ-12 for Satin Nickel.

BREAK DOWN Component Parts List

#	PART NAME	QTY
1	JEWEL LEVER HANDLE	2
2	TEFLON RING	2
3	ESCUTCHEON	2
4	TEFLON RING	2
5	SPACER / ADAPTER	2
6	RUBBER RING	2
7a	CARTRIDGE (COLD)	1
7b	CARTRIDGE (HOT)	1
8	RUBBER WASHER	2
9	LOCK NUT	2
10	VALVE	2
11	POP-UP ROD	1
12	SPOUT	1
13	SPOUT RING	1
14	QUICK CONNECT SHANK	1
15	METAL WASHER	1
16	LOCK NUT	1
17	T-CONNECTOR	1
18	AERATOR	1
19	HOSE	2

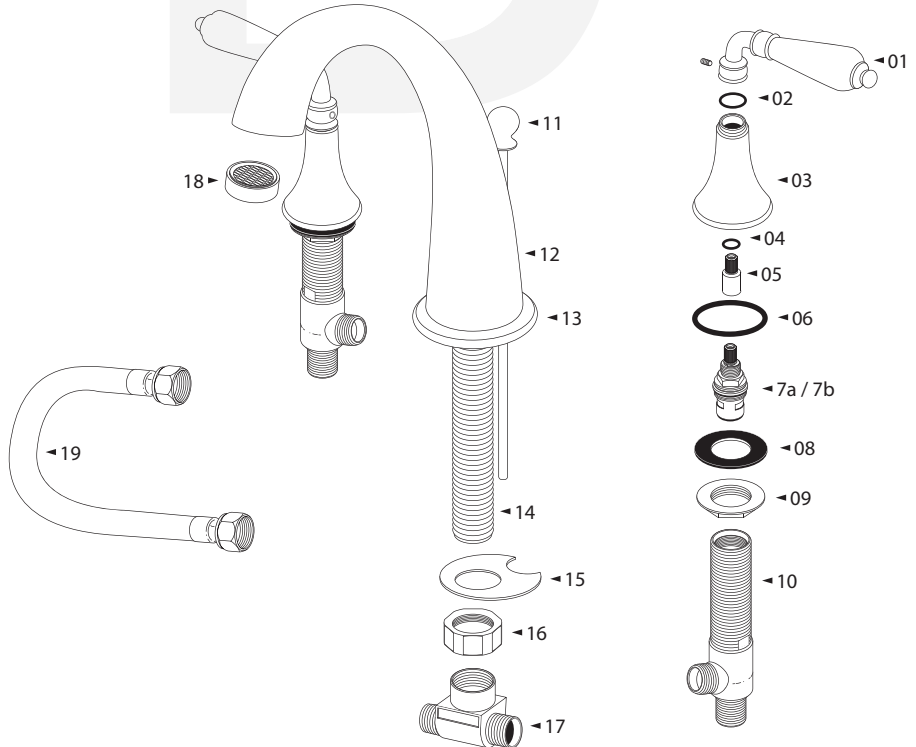

SPECIFIED MODEL - Handle Option

Handle Tip ML - xx	Handle Tip ML - xx	Handle Tip SC - xx	Handle Tip SC - xx
Escutcheons H - xx	Escutcheons J - xx	Escutcheons H - xx	Escutcheons J - xx
Handle option: HML	Handle option: JML	Handle option: HSC	Handle option: JSC

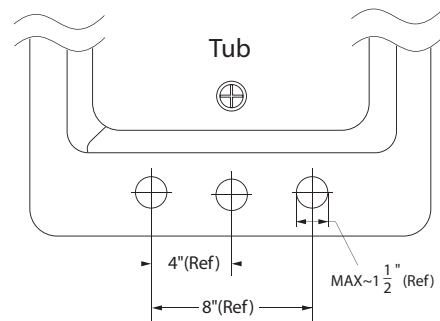
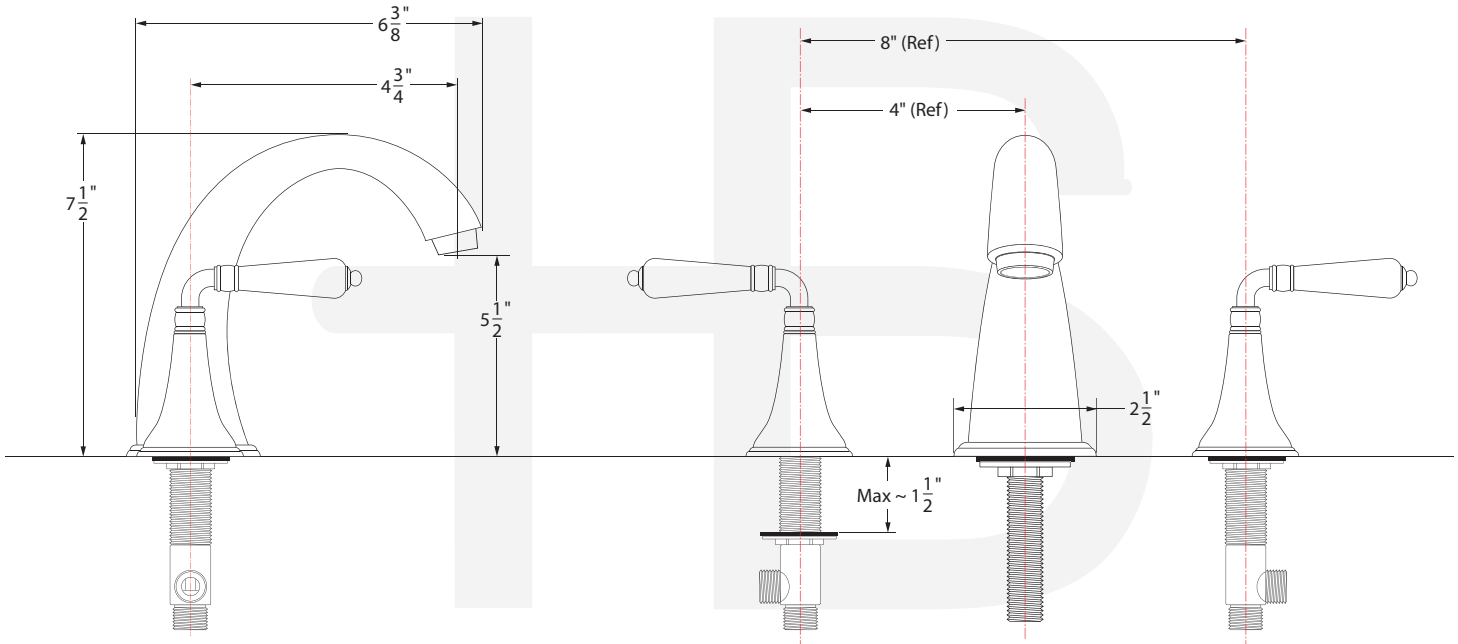

Item Number	Type	Date
JWWSxxHML	Wide Spread	10/30/09