



JEWEL - Roman Tub Filler

Description

- 3pc Roman Tub faucet
- Ceramic disc cartridges
- 3/4" S.S. braided hose
- 18 GPM @ 80 PSI

Standards

- ASME A112.18.1 Compliant
- Listed IAPMO / UPC & CUPC
- ADA Accessibility Guidelines for Buildings and Facilities - 4.27.4 Controls and Mechanisms (lever handle only)
- NSF - 61-9 tested and approved
- CSA B125.1 Compliant and listed



Colors / FinishES

- | | |
|---------------------|----------------------------|
| 01 - Chrome | 29 - Polished Nickel |
| 12 - Satin Nickel | 70 - Polished Brass (PVD) |
| 20 - Antique Bronze | 71 - Polished Nickel (PVD) |
| 21 - Antique Brass | 72 - Satin Nickel (PVD) |
| 22 - Antique nickel | 73 - Satin Brass (PVD) |
| 23 - Antique Copper | |
| 24 - Satin Copper | |
| 27 - Matte Nickel | |
| 28 - ORB | |

Please add finish code when placing order for parts with using following finish code table. For example J handle in Chrome will be BJ-01, BJ-12 for Satin Nickel.

Special Handle & Escutcheon Option

CBL / DJL / JBJ / JBL

BREAK DOWN Component Parts List

#	PART NAME	QTY
1a	JEWEL LEVER HANDLE	2
1b	CAMBRIDGE LEVER HANDLE	2
1c	LEXINGTON LEVER HANDLE	2
1d	DECORATIVE LEVER HANDLE	2
1e	METAL LEVER HANDLE	2
2	ESCUTCHEON	2
3	FLANGE	2
4	RUBBER RING	2
5a	CARTRIDGE (COLD)	1
5b	CARTRIDGE (HOT)	1
6	WASHER	2
7	LOCK NUT	2
8	VALVE BODY	1
9	SPOUT	1
10	QUICK CONNECT SHANK	1
11	WASHER	1
12	LOCK NUT	1
13	T-CONNECTOR	1
14	HOSE	2

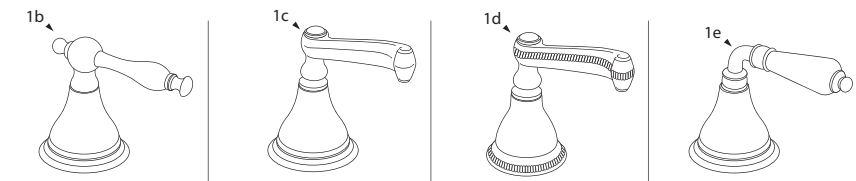
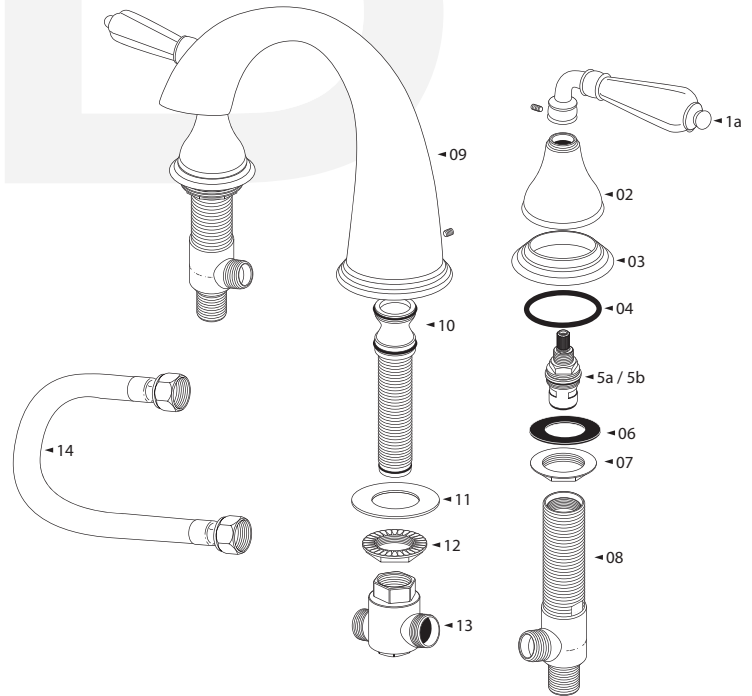

SPECIFIED MODEL - Handle Option

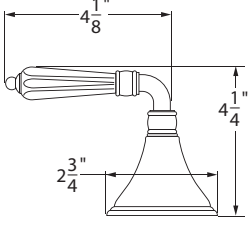
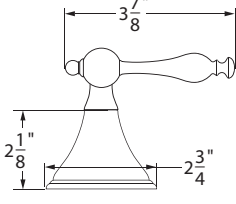
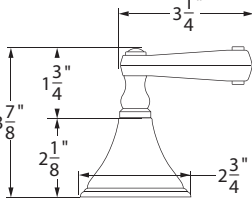
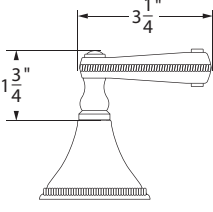
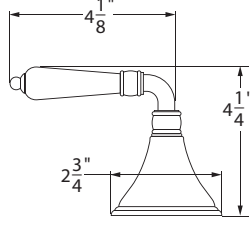
				
Handle Tip PL - xx	Handle Tip BL - xx	Handle Tip BJ - xx	Handle Tip JL - xx	Handle Tip ML - xx
Escutcheaons J - xx	Escutcheaons J - xx	Escutcheaons J - xx	Escutcheaons D - xx	Escutcheaons J - xx

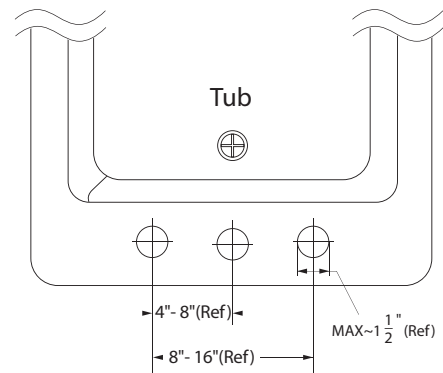
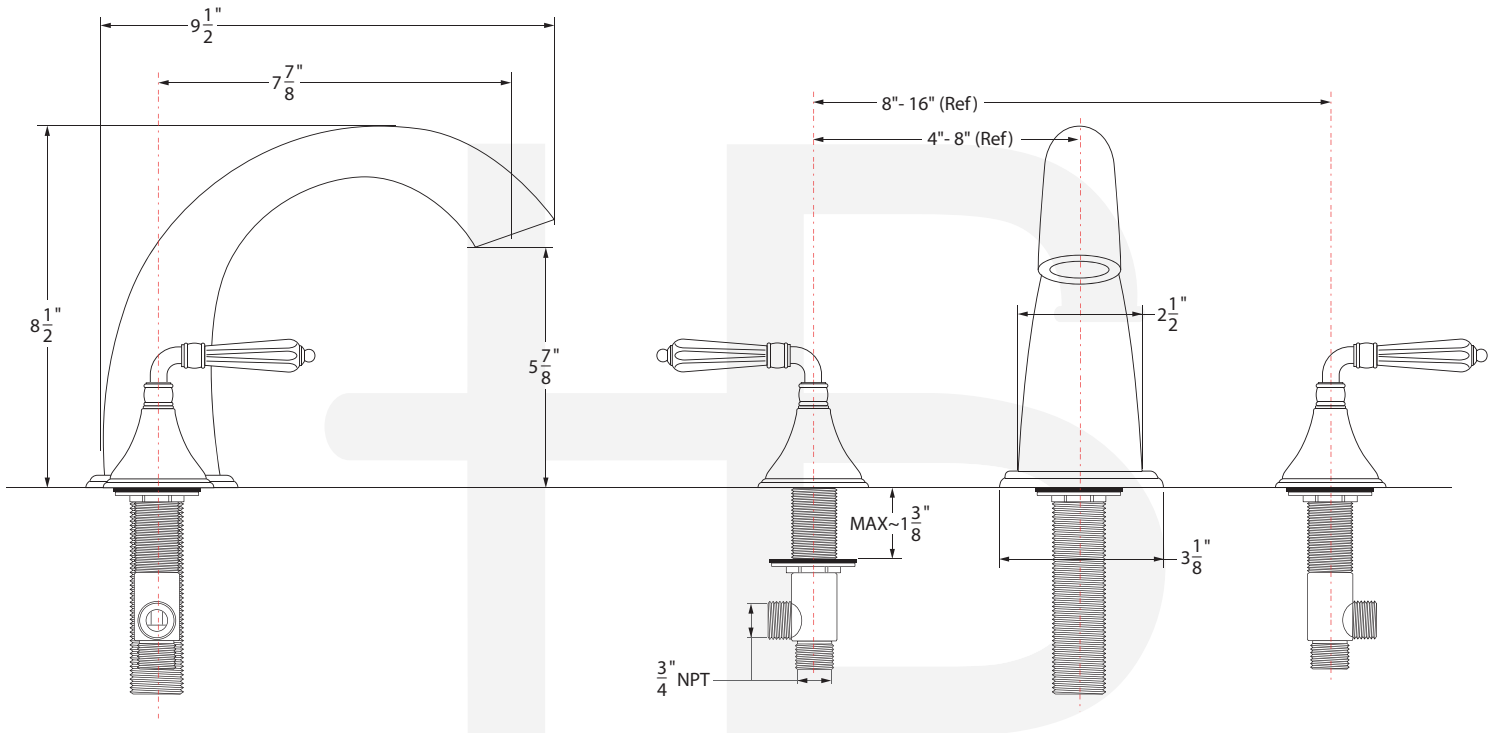

Item Number	Type	Date
JWRM	Roman Tub	07/29/2005