

FS20LGLCSS7

20.75" x 19.75" x 20.0" (H x W x D)

Commercially approved "cube" shaped compact all-freezer with a glass door, stainless steel cabinet, and front-mounted lock, capable of -20°C operation

Highlights:

Commercially approved for use in foodservice establishments

Glass door provides attractive view of stored products

-20° C capable for sensitive storage

Stainless steel cabinet adds durable luxury to any setting



| | |
|---------------------------------------|---|
| Commercially approved | ETL-S listed to ANSI-NSF Standard 7 and CalCode Compliant |
| Cube shaped | Square footprint for placement on top of counters |
| Fully wrapped stainless steel cabinet | 304 grade stainless steel wrapped cabinet for durability |
| Glass door | Heat resistant design provides clear view to promote impulse buys |
| Factory installed lock | Keyed lock for a secure interior |
| -20° C capable | Operates at safe temperature for storage of select sensitive material |
| Manual defrost | Static cooling system for improved temperature stability |
| One piece interior liner | Enjoy easy clean-up with a seamless liner that won't hold a mess in hidden crevices |
| Adjustable thermostat | Manage the interior temperature with ease and accuracy |
| 100% CFC free | Environmentally friendly design without ozone-damaging chemicals |

Specifications:

| | |
|------------------------|----------------|
| Height | 20.75" |
| Width | 19.75" |
| Depth | 20.0" |
| Capacity | 1.6 cu.ft. |
| Interior Height 1 | 14.5" |
| Interior Width 1 | 15.5" |
| Interior Depth 1 | 15.0" |
| Comp Step Height | 8.5" |
| Comp Step Width | 15.5" |
| Comp Step Depth | 7.0" |
| Shipping Weight | 75.0 lbs. |
| Weight | 70.0 lbs. |
| US Electrical Safety | UL |
| Voltage/Frequency | 115 V AC/60 Hz |
| Amps | 1.2 |
| Reversible | Yes |
| Door Swing | RHD |
| Shelf Quantity | 1 |
| Adjustable Shelf | true |
| Shelf Type | Wire |
| Defrost Type | Manual |
| Depth with door at 90° | 39.5" |
| Thermostat Type | Dial |
| Freon Oz | 3.17 |
| High Side PSI | 250.0 |
| Low Side PSI | 88.0 |
| Refrigerant Type | R134a |
| Compressor Warranty | 5 Years |
| Parts/Labor Warranty | 1 Year |
| Sanitation | ETL-S |

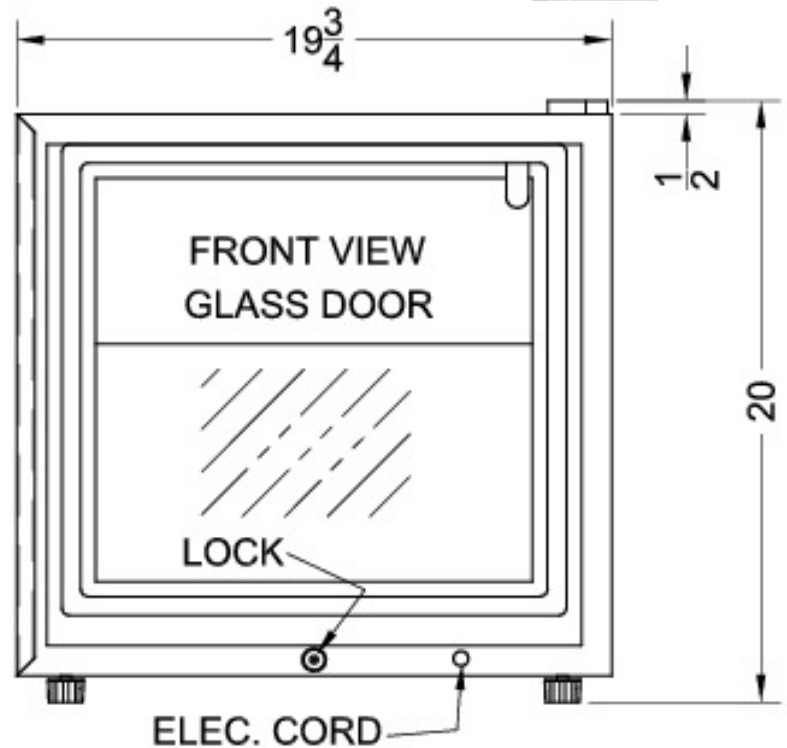
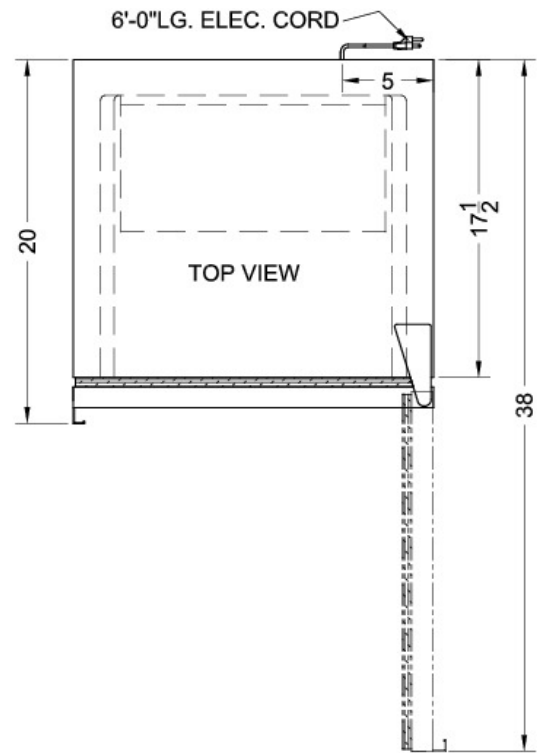

Summit Appliance Division, Felix Storch, Inc.
 770 Garrison Ave • Bronx, NY 10474
 Phone: 718-893-3900 • Fax: 718-842-3093
 Email: info@summitappliance.com