

FS20LGL7

20.75" x 19.75" x 20.0" (H x W x D)

Commercially approved "cube" shaped compact all-freezer with a glass door and front-mounted lock, capable of -20° C degree operation

Highlights:

- Glass door offers full view of stored products
- Commercially approved for use in foodservice establishments
- Convenient "cube" shape for easy placement above counters
- Factory-installed lock provides security you can count on



Commercially approved	ETL-S listed to ANSI-NSF Standard 7 and CalCode Compliant
Cube shaped	Square footprint for placement on top of counters
Fully finished white cabinet	Allows the unit to be used freestanding
Glass door	Heat resistant design provides clear view to promote impulse buys
Factory installed lock	Keyed lock for a secure interior
-20° C capable	Operates at safe temperature for storage of select sensitive material
Manual defrost	Static cooling system for improved temperature stability
One piece interior liner	Easy clean-up with a seamless liner that won't hold a mess in hidden crevices
Adjustable thermostat	Manage the interior temperature with ease and accuracy
100% CFC free	Environmentally friendly design without ozone-damaging chemicals

Specifications:

Height	20.75"
Width	19.75"
Depth	20.0"
Capacity	1.6 cu.ft.
Ext Depth with Handle	20.0"
Interior Height 1	14.5"
Interior Width 1	15.5"
Interior Depth 1	15.0"
Comp Step Height	8.5"
Comp Step Width	15.5"
Comp Step Depth	7.0"
Shipping Weight	68.0 lbs.
Amps	1.43
US Electrical Safety	UL
Voltage/Frequency	115 V AC/60 Hz
Reversible	Yes
Door Swing	RHD
Shelf Quantity	1
Adjustable Shelf	true
Defrost Type	Manual
Depth with door at 90°	38.0"
Height to Hinge Cap	20.0"
Thermostat Type	Dial
Freon Oz	3.17
Low Side PSI	88.0
Refrigerant Type	R134a
High Side PSI	250.0
Level Legs Quantity	2
Parts/Labor Warranty	1 Year
Compressor Warranty	5 Years
Sanitation	ETL-S

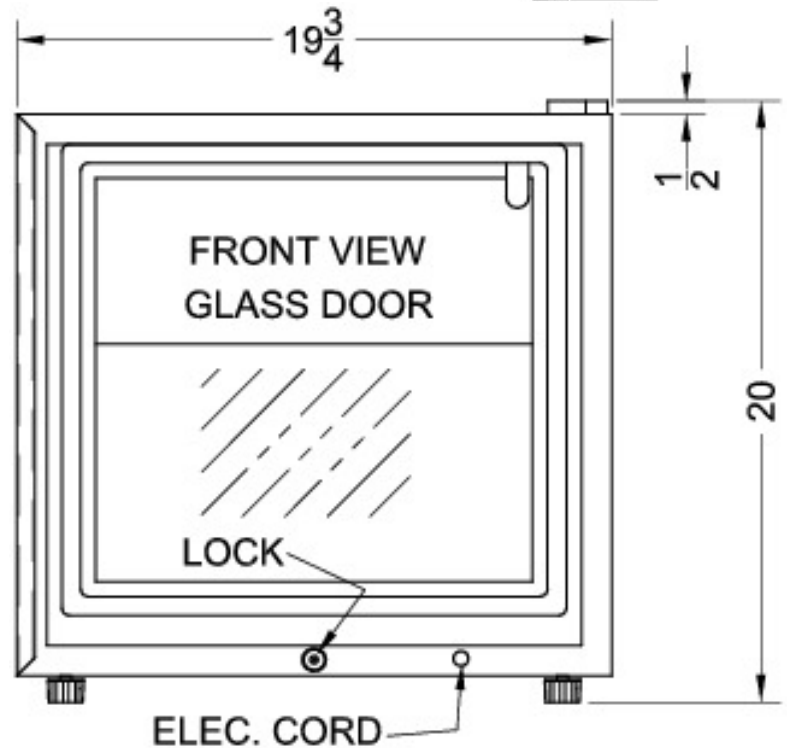
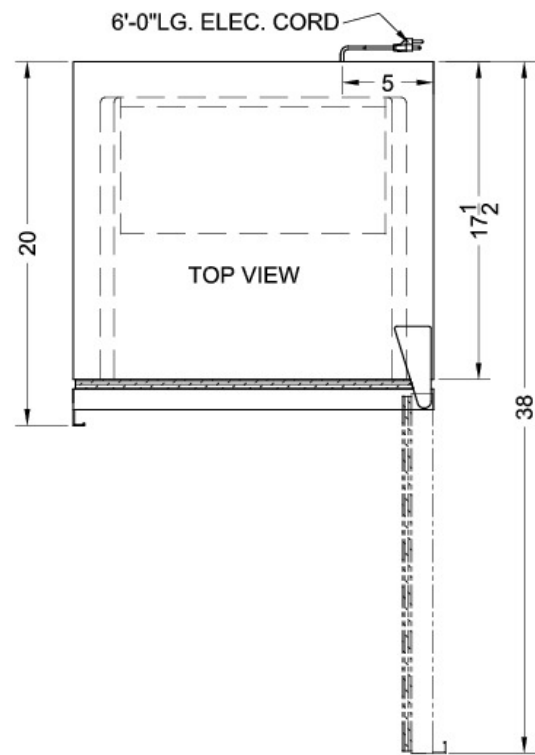

Summit Appliance Division, Felix Storch, Inc.
 770 Garrison Ave • Bronx, NY 10474
 Phone: 718-893-3900 • Fax: 718-842-3093
 Email: info@summitappliance.com