

## FS20L7

19.75" x 19.75" x 19.38" (H x W x D)

Commercially approved "cube" shaped compact all-freezer with a front mounted lock, capable of -20° C degree operation

### Highlights:

ETL-S listed to NSF-7 commercial standards

Factory-installed lock provides security you can count on

Seamless interior liner simplifies cleanup

-20° C capable for sensitive storage



Commercially approved	ETL-S listed to ANSI-NSF Standard 7 and CalCode Compliant
Cube shaped	Square footprint for placement on top of counters
Fully finished white cabinet	Allows the unit to be used freestanding
Factory installed lock	Keyed lock for a secure interior
-20° C capable	Operates at safe temperature for storage of select sensitive material
Manual defrost	No temperature fluctuations with a manual defrost system that keeps the cold inside
One piece interior liner	Easy clean-up with a seamless liner that won't hold a mess in hidden crevices
Adjustable thermostat	Manage the interior temperature with ease and accuracy
Flat door liner	Interior design conforms to CDC guidelines to ensure stable conditions for sensitive materials
Reversible door	Keep your options flexible with a reversible door that is easy to switch when your arrangement changes

## Specifications:

Height	19.75"
Width	19.75"
Depth	19.38"
Capacity	1.6 cu.ft.
Interior Height 1	14.5"
Interior Width 1	15.5"
Interior Depth 1	15.0"
Comp Step Height	8.5"
Comp Step Width	15.5"
Comp Step Depth	7.0"
Shipping Weight	55.0 lbs.
US Electrical Safety	UL
Voltage/Frequency	115 V AC/60 Hz
Amps	1.43
Canadian Electrical Safety	ULC
Reversible	Yes
Door Swing	RHD
Shelf Quantity	1
Adjustable Shelf	true
Defrost Type	Manual
Depth with door at 90°	37.88"
Thermostat Type	Dial
Freon Oz	3.17
Refrigerant Type	R134a
High Side PSI	250.0
Low Side PSI	88.0
Level Legs Quantity	2
Compressor Warranty	5 Years
Parts/Labor Warranty	1 Year
Sanitation	ETL-S

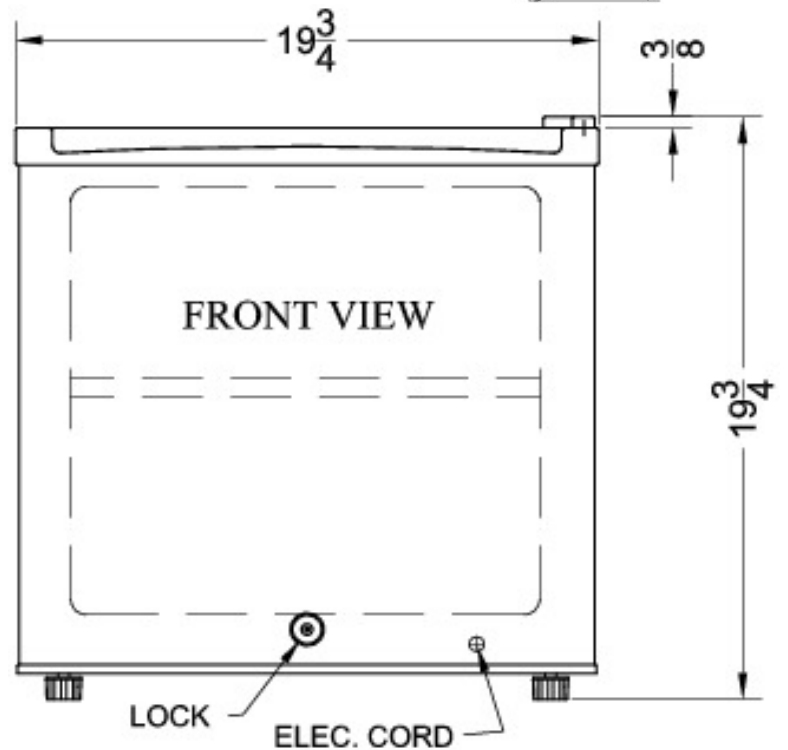
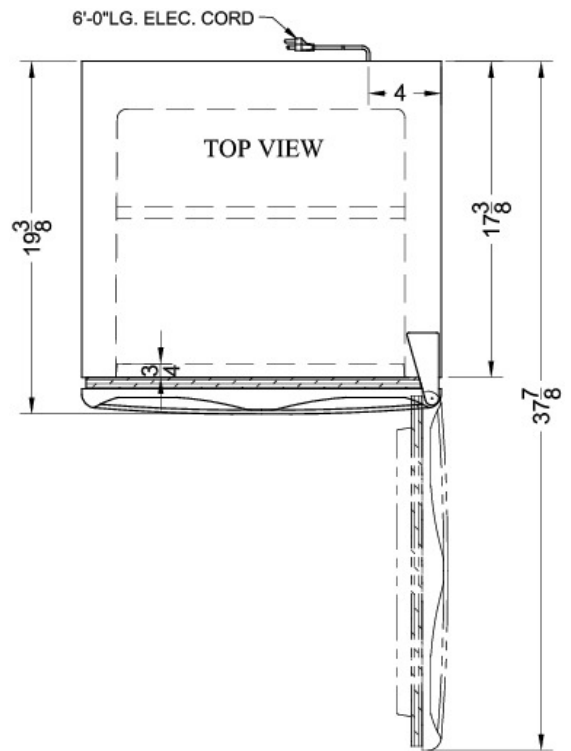

Summit Appliance Division, Felix Storch, Inc.  
 770 Garrison Ave • Bronx, NY 10474  
 Phone: 718-893-3900 • Fax: 718-842-3093  
 Email: info@summitappliance.com