

FFAR2L

19.75" x 19.75" x 21.0" (H x W x D)

Compact auto defrost all-refrigerator with lock for general purpose/medical use

Highlights:

Compact size is ideal for countertop use

Automatic defrost saves you time and maintenance

Factory-installed lock provides security you can depend on

Designed for general purpose use in medical and scientific facilities



Cube size	Compact fit for easy use on top of counters
Front-mounted lock	Keyed lock for a secure interior
Automatic defrost	Reduced maintenance with auto defrost system
No internal fans	Static cooling system
One piece interior liner	Enjoy easy clean-up with a seamless liner that won't hold a mess in hidden crevices
Door storage	Store large bottles right on the door for easy access
Reversible door	User reversible door swing
Adjustable thermostat	Manage your food's temperature with ease and accuracy
100% CFC	Environmentally friendly design without ozone-damaging chemicals

Specifications:

Height	19.75"
Width	19.75"
Depth	21.0"
Capacity	1.8 cu.ft.
Ext Depth with Handle	21.0"
Interior Height 1	15.75"
Interior Width 1	16.75"
Interior Depth 1	15.5"
Comp Step Height	7.5"
Comp Step Width	16.75"
Comp Step Depth	6.5"
Shipping Weight	55.0 lbs.
Voltage/Frequency	115 V AC/60 Hz
Amps	1.2
Energy Usage/Year	318.0 kWh/year
US Electrical Safety	UL
Canadian Electrical Safety	ULC
Reversible	Yes
Door Swing	RHD
Shelf Quantity	1
Adjustable Shelf	true
Shelf Type	Wire
Full Door Shelf Quantity	1
Half Door Shelf Quantity	1
Defrost Type	Automatic
Depth with door at 90°	39.5"
Thermostat Type	Dial
Low Side PSI	88.0
Freon Oz	1.84
Refrigerant Type	R134a
Level Legs Quantity	2
High Side PSI	250.0
Parts/Labor Warranty	1 Year
Compressor Warranty	5 Years

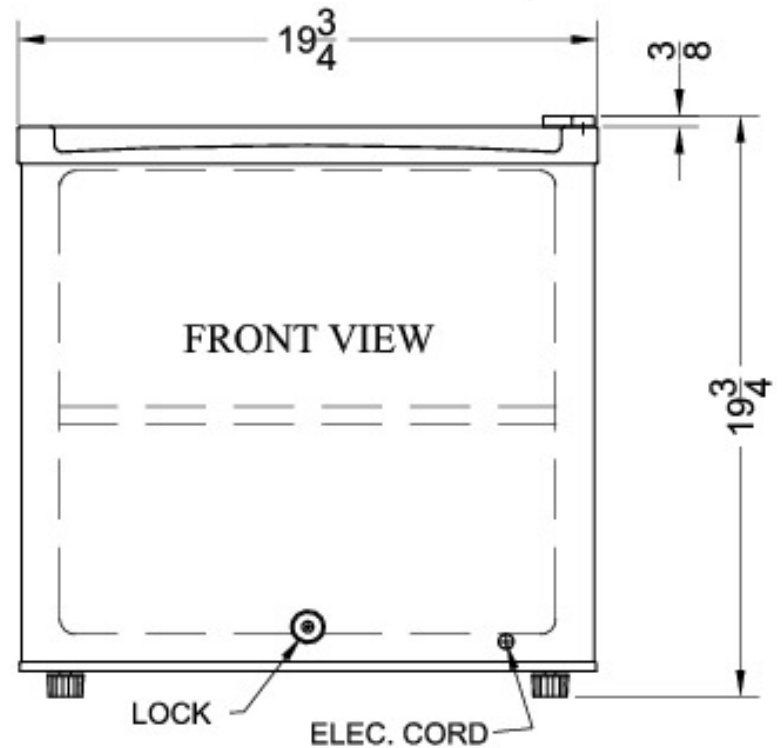
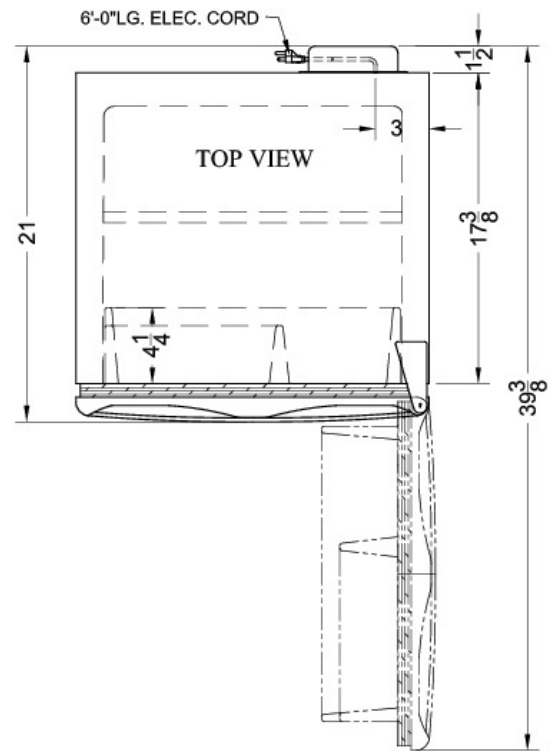

Summit Appliance Division, Felix Storch, Inc.
 770 Garrison Ave • Bronx, NY 10474
 Phone: 718-893-3900 • Fax: 718-842-3093
 Email: info@summitappliance.com