

FFAR2L7

19.75" x 19.75" x 21.0" (H x W x D)

Commercially approved "cube" sized all-refrigerator with auto defrost and front lock for general purpose use

Highlights:

- ETL-S listed to NSF standards for use in commercial settings
- Factory-installed lock provides security you can count on
- Compact "cube" size for easy placement
- Automatic defrost saves on user maintenance



Commercially approved	ETL-S listed to ANSI-NSF Standard 7
Cube shaped	Compact fit for easy use on top of counters
Factory installed lock	Keyed lock for a secure interior
Fully finished white cabinet	Allows the refrigerator to be used freestanding
Automatic defrost	Reduced user maintenance with auto defrost system
One piece interior liner	Easy clean-up with a seamless liner that won't hold a mess in hidden crevices
Removable shelf	Rearrange your refrigerator space to accommodate all shapes and sizes or remove shelves for a simple clean-up
Door shelves	Store large bottles right on the door for easy access
Adjustable thermostat	Manage the interior temperature with ease and accuracy
100% CFC free	Environmentally friendly design without ozone-damaging chemicals

Specifications:

Height	19.75"
Width	19.75"
Depth	21.0"
Capacity	1.8 cu.ft.
Ext Depth with Handle	21.0"
Interior Height 1	15.75"
Interior Width 1	16.75"
Interior Depth 1	15.5"
Comp Step Height	7.5"
Comp Step Width	16.75"
Comp Step Depth	6.5"
Shipping Weight	55.0 lbs.
Other Energy Info	115V / 60Hz
US Electrical Safety	UL
Amps	1.2
Energy Usage/Year	318.0 kWh/year
Voltage/Frequency	115 V AC/60 Hz
Canadian Electrical Safety	ULC
Reversible	Yes
Door Swing	RHD
Shelf Quantity	1
Adjustable Shelf	true
Shelf Type	Wire
Full Door Shelf Quantity	1
Half Door Shelf Quantity	1
Defrost Type	Automatic
Depth with door at 90°	39.5"
Thermostat Type	Dial
Freon Oz	1.84
Level Legs Quantity	2
High Side PSI	250.0
Low Side PSI	88.0
Refrigerant Type	R134a
Compressor Warranty	5 Years
Parts/Labor Warranty	1 Year
Sanitation	ETL-S

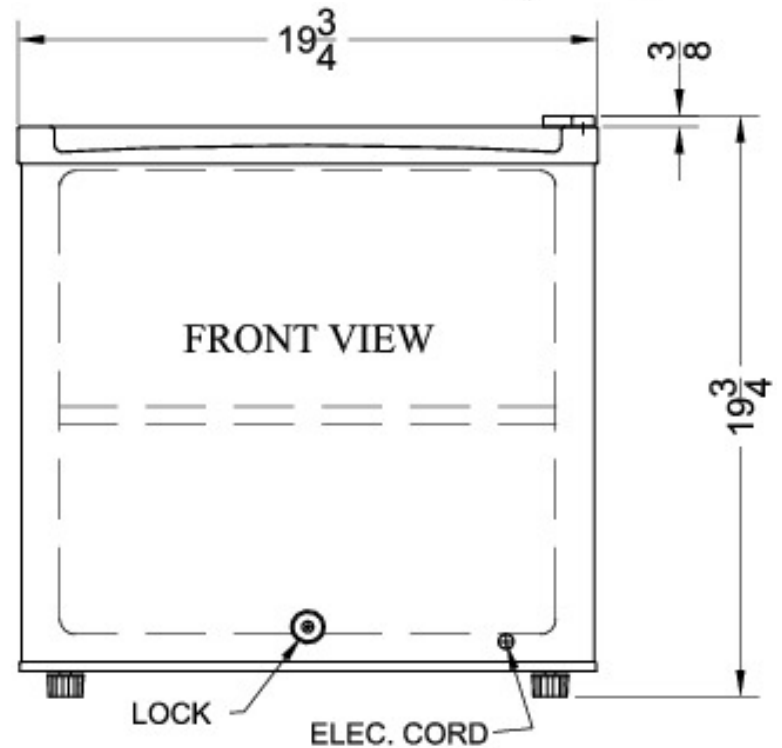
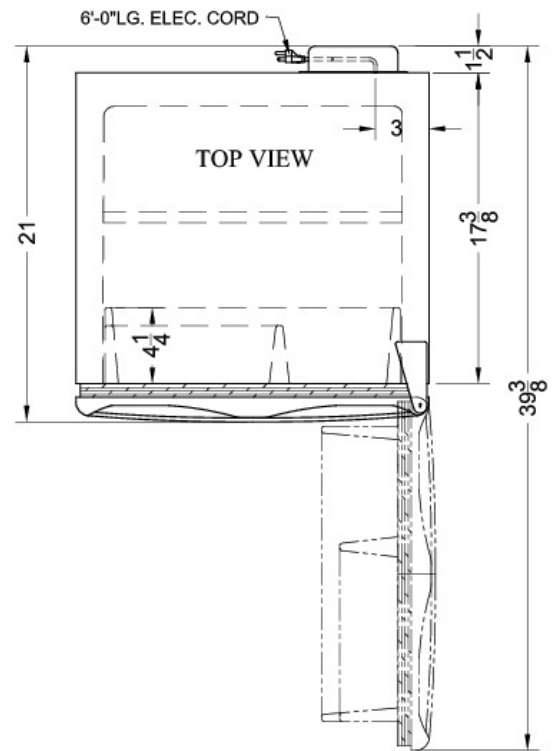

Summit Appliance Division, Felix Storch, Inc.
 770 Garrison Ave • Bronx, NY 10474
 Phone: 718-893-3900 • Fax: 718-842-3093
 Email: info@summitappliance.com