

FF71

46.0" x 18.75" x 23.0" (H x W x D)

Two-door frost-free refrigerator-freezer in slim 18" width and ADA compliant 46" height

Highlights:

- Slim width packs full capacity into tight spaces
- True frost-free operation saves you maintenance by preventing icy buildup
- Two-door design for convenience and efficiency in compact size
- 46" height for select ADA compliant applications



Frost-free operation	No-frost convenience for reduced user maintenance
Thin-line design	Slim width under 19" fits easily in the tightest spaces
Clear crisper	Get the longest life and best taste out of produce by storing greens in a convenient slide drawer
Interior light	Automatically illuminates when you open the door
Adjustable shelves	Rearrange your refrigerator space to accommodate all shapes and sizes or remove shelves for a simple clean-up
Full freezer shelf	Organize your freezer contents with more options
Door storage	Keep large bottles and condiments right on the door for easy access
Reversible doors	Keep your options flexible with reversible doors that are easy to switch when your arrangement changes
Adjustable thermostat	Manage the interior temperature with ease and accuracy
ADA compliant	46 inch height makes both the refrigerator and freezer accessible under ADA guidelines

Specifications:

Height	46.0"
Width	18.75"
Depth	23.0"
Capacity	4.8 cu.ft.
Shipping Weight	130.0 lbs.
Weight	102.0 lbs.
Canadian Electrical Safety	ULC
Voltage/Frequency	115 V AC/60 Hz
US Electrical Safety	UL
Energy Usage/Year	329.0 kWh/year
Reversible	Yes
Door Swing	RHD
Crisper Quantity	1
Shelf Quantity	3
Adjustable Shelf	true
Shelf Type	Wire
Crisper Cover Type	Glass
Crisper Finish	Transparent
Full Door Shelf Quantity	5
Defrost Type	Frost-Free
Depth with door at 90°	40.0"
Thermostat Type	Dial
Light	true
Fan Type	Interior
Refrigerant Type	R134a
Level Legs Quantity	2
Compressor Warranty	5 Years
Parts/Labor Warranty	1 Year

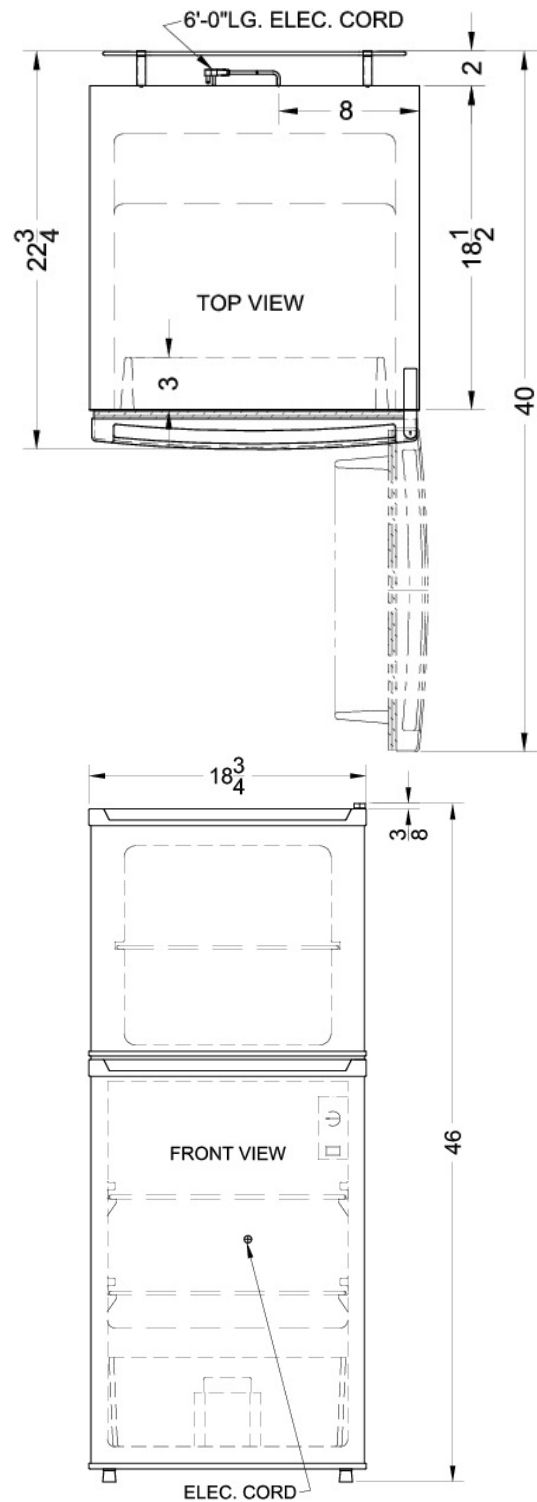

Summit Appliance Division, Felix Storch, Inc.
 770 Garrison Ave • Bronx, NY 10474
 Phone: 718-893-3900 • Fax: 718-842-3093
 Email: info@summitappliance.com