

FF511LMED

33.25" x 19.38" x 22.0" (H x W x D)

20" wide counter height all-refrigerator for medical use, with internal fan, lock, temperature alarm, and hospital grade plug; Replaces FF510LMED

Highlights:

- Fully featured for use in medical and laboratory facilities
- Includes a hospital grade cord with a 'green dot' plug
- Internal fan ensures evenly cooled interior
- High temperature alarm with external temperature readout



Slim 20" width	Full 4.1 cu.ft. capacity inside conveniently slim footprint
Automatic defrost	Reduced maintenance with auto defrost system
Internal fan	Fan-forced cooling ensures the unit is evenly cooled from top to bottom
Factory installed lock	Top-mounted for convenient security
Fully finished white cabinet	Allows the unit to be used freestanding
Hospital grade cord with 'green dot' plug	Secure three-pronged cord for added unit safety
High temperature alarm	Warns of temperature fluctuations and includes an external temperature readout on the door
Adjustable shelves	Rearrange refrigerator space to accommodate all sizes or remove shelves for simple cleanup
Flat door liner	Easy to clean, with more depth for storage
Interior light	Turn the light on and off with a convenient rocker switch

Specifications:

Height	33.25"
Width	19.38"
Depth	22.0"
Capacity	4.1 cu.ft.
Interior Height 1	29.0"
Interior Width 1	17.0"
Interior Depth 1	17.0"
Comp Step Height	8.0"
Comp Step Width	17.0"
Comp Step Depth	6.75"
Shipping Weight	85.0 lbs.
Weight	64.0 lbs.
Canadian Electrical Safety	ETL-C
US Electrical Safety	ETL
Amps	1.4
Voltage/Frequency	115 V AC/60 Hz
Reversible	Factory Reversible
Door Swing	RHD
Shelf Quantity	3
Adjustable Shelf	true
Shelf Type	Wire
Defrost Type	Automatic
Fan Type	Interior
Light	true
Thermostat Type	Dial
Low Side PSI	103.0
Freon Oz	1.75
Refrigerant Type	R134a
Level Legs Quantity	2
High Side PSI	205.0
Parts/Labor Warranty	1 Year
Compressor Warranty	5 Years

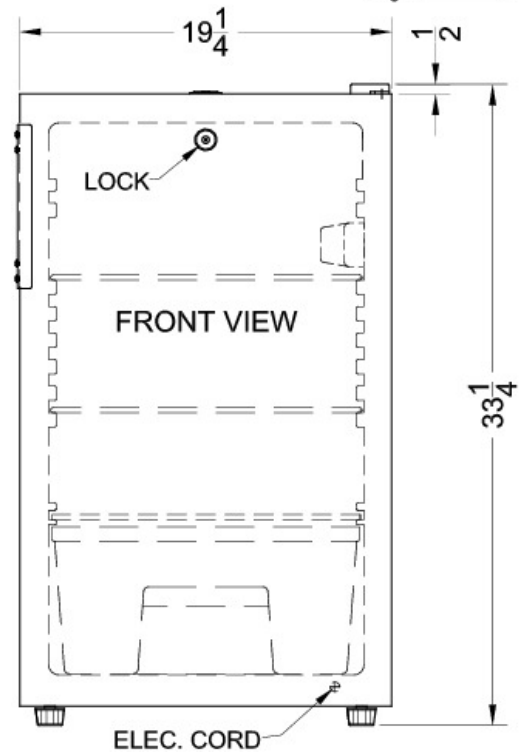
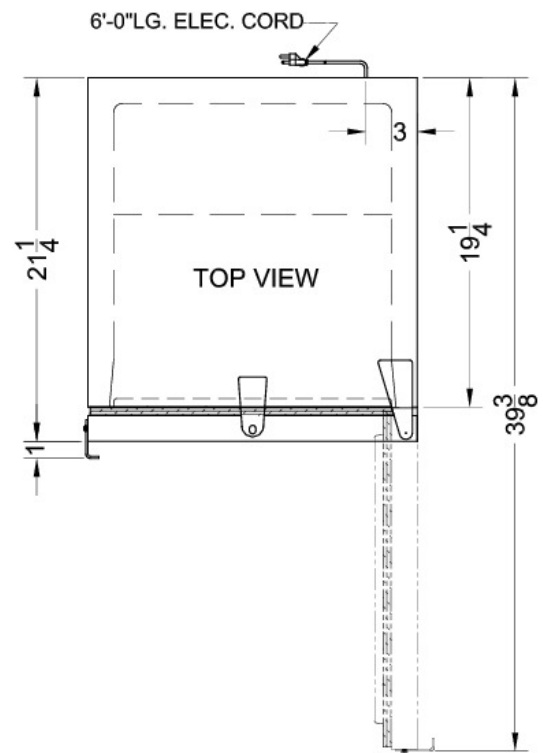

Summit Appliance Division, Felix Storch, Inc.
 770 Garrison Ave • Bronx, NY 10474
 Phone: 718-893-3900 • Fax: 718-842-3093
 Email: info@summitappliance.com