

FS20L

19.75" x 19.75" x 19.38" (H x W x D)

Compact -20°C all-freezer with lock

Highlights:

- 20° C capable for sensitive storage
- Seamless interior liner simplifies cleanup
- Factory-installed lock provides security you can count on
- Convenient "cube" shape for easy placement



Cube shaped	Square footprint for placement on top of counters
Fully finished white cabinet	Allows the unit to be used freestanding
Factory installed lock	Keyed lock for a secure interior
-20° C capable	Operates at safe temperature for storage of select sensitive material
Flat door liner	Interior design conforms to CDC guidelines to ensure stable conditions for sensitive materials
Manual defrost	Static cooling system for improved temperature stability
One piece interior liner	Easy clean-up with a seamless liner that won't hold a mess in hidden crevices
Adjustable thermostat	Manage the interior temperature with ease and accuracy
Reversible door	Keep your options flexible with a reversible door that is easy to switch when your arrangement changes
100% CFC free	Environmentally friendly design without ozone-damaging chemicals

FS20L Specifications:

Height	19.75"
Width	19.75"
Depth	19.38"
Capacity	1.6 cu.ft.
Interior Height 1	14.5"
Interior Width 1	15.5"
Interior Depth 1	15.0"
Comp Step Height	8.5"
Comp Step Width	15.5"
Comp Step Depth	7.0"
Shipping Weight	55.0 lbs.
Voltage/Frequency	115 V AC/60 Hz
Amps	1.43
Canadian Electrical Safety	ULC
US Electrical Safety	UL
Reversible	Yes
Door Swing	RHD
Shelf Quantity	1
Adjustable Shelf	true
Defrost Type	Manual
Depth with door at 90°	37.88"
Thermostat Type	Dial
Low Side PSI	88.0
Freon Oz	3.17
Refrigerant Type	R134a
Level Legs Quantity	2
High Side PSI	250.0
Parts/Labor Warranty	1 Year
Compressor Warranty	5 Years

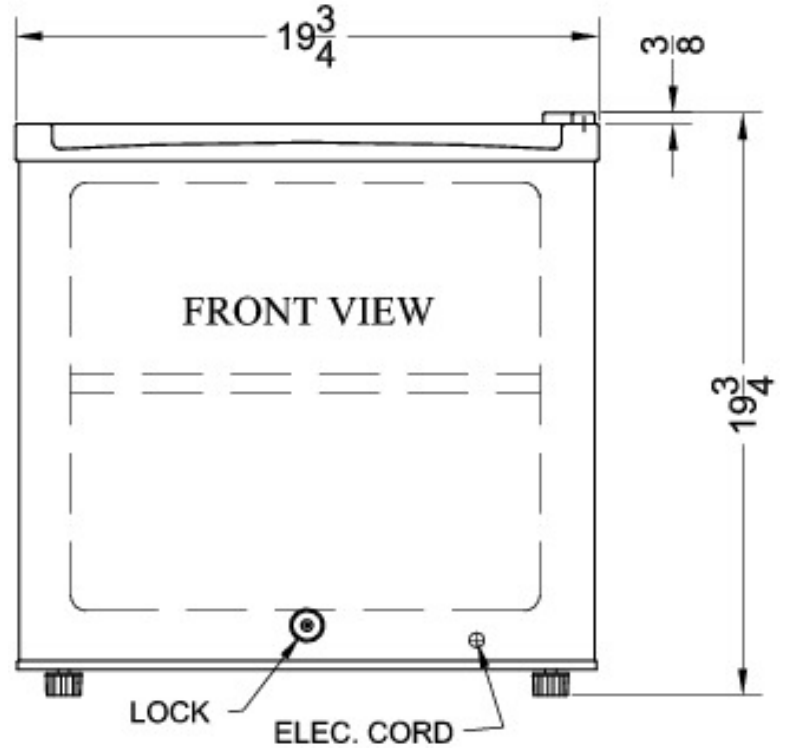
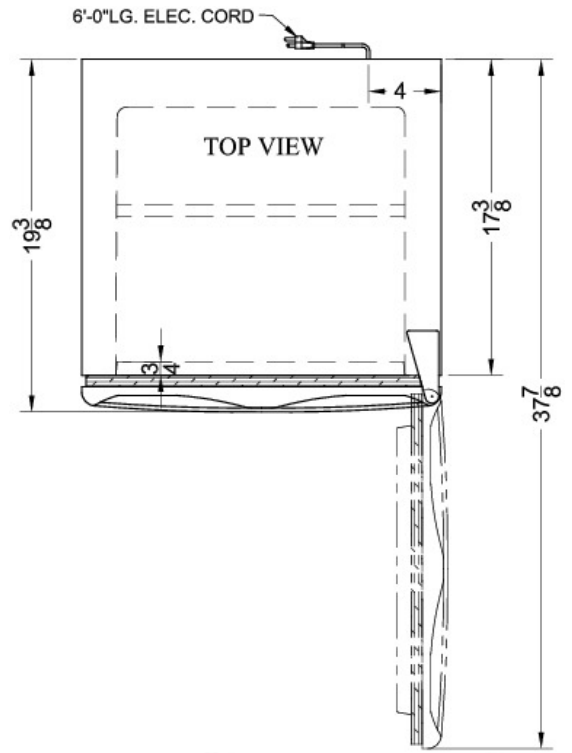

Summit Appliance Division, Felix Storch, Inc.
 770 Garrison Ave • Bronx, NY 10474
 Phone: 718-893-3900 • Fax: 718-842-3093
 Email: info@summitappliance.com