

SCFF51OSWHMED

34.0" x 23.63" x 23.5" (H x W x D)

Frost-free all-freezer for built-in or freestanding general purpose use, with digital thermostat, temperature alarm, lock, and green dot cord

Highlights:

- Designed for medical and general purpose storage
- Digital thermostat allows easy temperature management
- Temperature alarm warns when unit is out of range
- Factory-installed lock offers security you can count on



Frost-free operation	No-frost convenience eliminates the need to manually defrost the unit
Built-in capable	Make the best use of space by installing your freezer under the counter and flush with other cabinets
Temperature alarm	High/low temperature alarm audibly warns when interior is out of set range
Fully finished cabinet	Allows the freezer to be used as a freestanding model
Hospital grade cord with 'green dot' plug	Secure three-pronged cord for added unit safety
Digital thermostat	Electronic controls offer easy and intuitive temperature management
Adjustable shelves	Rearrange your freezer space to accommodate all shapes and sizes or remove shelves for a simple clean-up
Factory installed lock	Keyed lock for a secure interior
Commercially approved	ETL-S listed to NSF-7 Standards for use in commercial establishments
100% CFC free	Environmentally friendly design without ozone-damaging chemicals

SCFF51OSWHMED Specifications:

Height	34.0"
Width	23.63"
Depth	23.5"
Capacity	4.72 cu.ft.
Ext Depth with Handle	25.35"
Shipping Weight	98.0 lbs.
Weight	88.0 lbs.
Canadian Electrical Safety	ETL-C
Amps	2.0
US Electrical Safety	ETL
Voltage/Frequency	115 V AC/60 Hz
Reversible	Yes
Door Swing	RHD
Shelf Quantity	3
Adjustable Shelf	true
Shelf Type	Chrome
Defrost Type	Frost-Free
Depth with door at 90°	45.63"
Thermostat Type	Digital
Light	true
Fan Type	Interior and Exterior
Low Side PSI	106.0
Refrigerant Type	R134a
High Side PSI	270.0
Freon Oz	2.8
Compressor Warranty	5 Years
Parts/Labor Warranty	1 Year
Sanitation	ETL-S

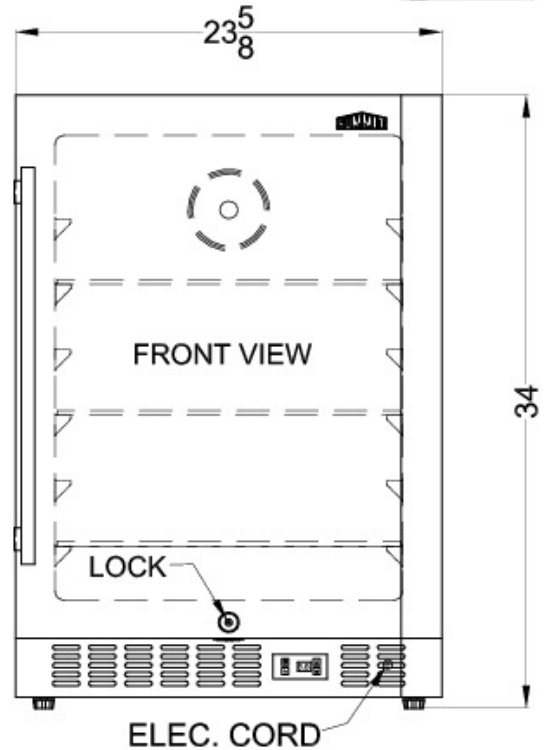
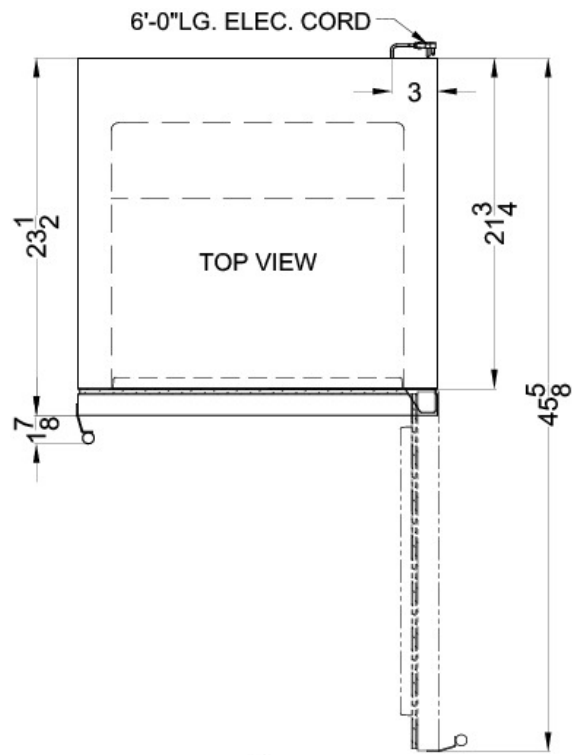

Summit Appliance Division, Felix Storch, Inc.
 770 Garrison Ave • Bronx, NY 10474
 Phone: 718-893-3900 • Fax: 718-842-3093
 Email: info@summitappliance.com