

FF28LWHVAC

24.5" x 18.5" x 17.75" (H x W x D)

Compact medical all-refrigerator for temperature stable medical storage, with digital thermostat, lock, self-closing door, temperature alarm, and internal fan

Highlights:

- Medical grade design conforms with CDC guidelines for vaccine storage
- Specialized interior design protects stored contents when the door is open
- Automatic defrost with an internal fan for stabilized cooling designed to stay within 2°C of set temperature
- High/low temperature alarm includes NIST calibrated temperature readout of the interior



Improved temperature stability	Interior is designed to operate within 2°C of set temperature performance
Interior drawer covers	Two shelves are protected by metal door flaps that help to protect stored contents from being exposed to room temperature when the door is opened
Digital thermostat	Electronic controls ensure precise and intuitive temperature management
High/low temperature alarm	Audible alarm sounds if the interior temperature rises or falls out of set range
NIST calibrated temperature display	Alarm includes NIST calibrated display of the current interior and high/low temperature
Self-closing door	Door closes automatically when opened at angles less than 90° to prevent the interior from being exposed to room temperature
Access port with dry contact	Pre-installed probe with dry contact allows users to install their own monitoring equipment; customers can specify placement of the access port upon order
Hospital grade cord and plug	Secure three-pronged 'green dot' cord for added unit safety in high traffic settings
Automatic defrost	Reduced maintenance with auto defrost system
Internal fan	Fan-cooled interior maintains a consistent temperature from top to bottom

FF28LWHVAC Specifications:

Height	24.5"
Width	18.5"
Depth	17.75"
Capacity	0.8 cu.ft.
Interior Height 1	5.38"
Interior Width 1	14.0"
Interior Depth 1	10.5"
Interior Height 2	6.0"
Interior Width 2	14.0"
Interior Depth 2	8.0"
Shipping Weight	90.0 lbs.
Weight	60.0 lbs.
Amps	1.3
Canadian Electrical Safety	ETL-C
Voltage/Frequency	115 V AC/60 Hz
US Electrical Safety	ETL
Reversible	Factory Reversible
Door Swing	RHD
Defrost Type	Automatic
Depth with door at 90°	34.5"
Height to Hinge Cap	24.88"
Thermostat Type	Digital
Fan Type	Interior
Refrigerant Type	R134a
Level Legs Quantity	2
Freon Oz	1.3
High Side PSI	261.0
Low Side PSI	103.0
Compressor Warranty	5 Years
Parts/Labor Warranty	1 Year

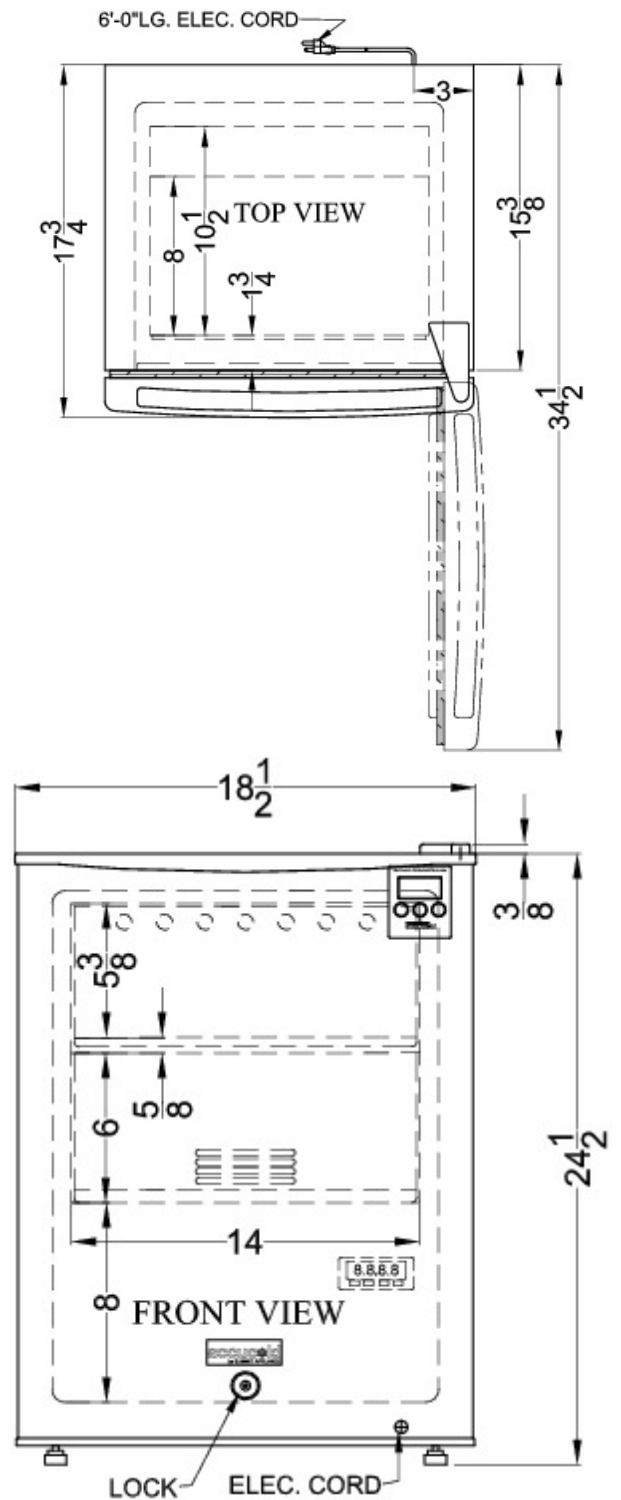

Summit Appliance Division, Felix Storch, Inc.
 770 Garrison Ave • Bronx, NY 10474
 Phone: 718-893-3900 • Fax: 718-842-3093
 Email: info@summitappliance.com