

BIM44GADA

32.38" x 14.5" x 23.5" (H x W x D)

ADA compliant NSF-listed auto defrost icemaker for built-in or freestanding use under counters

Highlights:

32 3/8" height fits under lower ADA compliant counters

Automatic defrost saves on user maintenance

Flexible design allows built-in or freestanding use

Slim 15" width fits any tight spot



ADA compliant	32 3/8" height fits under lower ADA compliant counters. NOTE: Height with hinge cap reaches 33". If installing under ADA compliant counters, please take the hinge cap into account when planning for this unit
Commercially approved	NSF listed for use in commercial establishments
ENERGY STAR qualified	Certified as a batch-type commercial icemaker for its efficiency
Automatic defrost	Simplify appliance care by letting your icemaker defrost itself
Reversible door	Keep your options flexible with a reversible door that is easy to switch when your arrangement changes; Unit ships LHD but can be reversed in our factory or by the user
Built-in capable	Make the best use of space by installing your icemaker under the counter and flush with other cabinets
Stainless steel door	Professional styling with lasting durability
Professional towel bar handle	A curved handle in brushed stainless steel offers an easy grip

Fully finished
black cabinet

Allows the icemaker to be used as a freestanding model

Insulated
storage bin

Ice stays solid longer in this cold-protected bin

BIM44GADA Specifications:

Height	32.38"
Width	14.5"
Depth	23.5"
Ext Depth with Handle	25.0"
Interior Height 1	18.5"
Interior Width 1	12.0"
Interior Depth 1	16.0"
Shipping Weight	117.0 lbs.
Canadian Electrical Safety	ULC
Voltage/Frequency	115 V AC/60 Hz
Amps	4.8
US Electrical Safety	UL
Reversible	Yes
Door Swing	LHD
Defrost Type	Automatic
Depth with door at 90°	37.0"
Height to Hinge Cap	33.0"
Thermostat Type	Dial
Freon Oz	3.88
Refrigerant Type	R134a
Low Side PSI	130.0
High Side PSI	350.0
Compressor Warranty	5 Years
Parts/Labor Warranty	1 Year
Sanitation	NSF

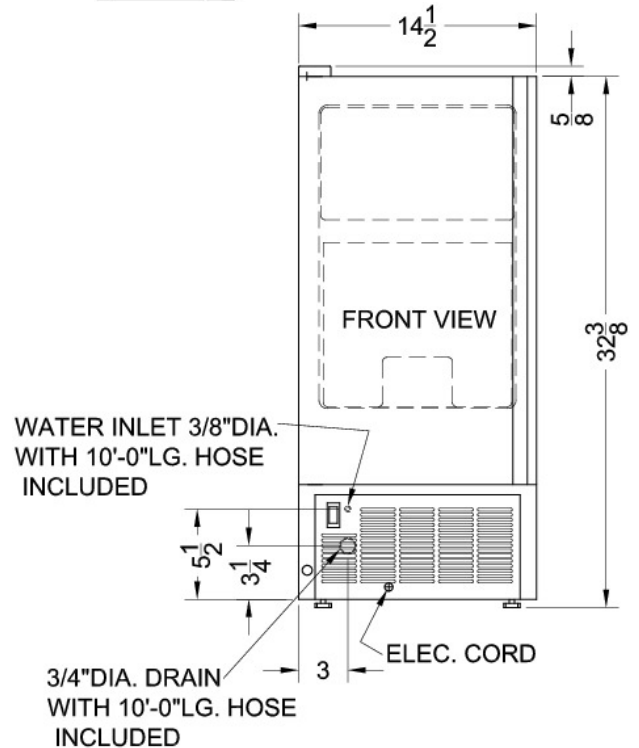
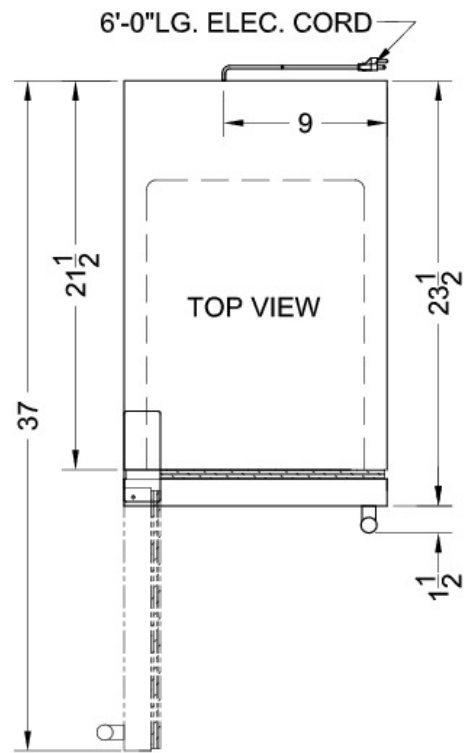

Summit Appliance Division, Felix Storch, Inc.
 770 Garrison Ave • Bronx, NY 10474
 Phone: 718-893-3900 • Fax: 718-842-3093
 Email: info@summitappliance.com