

MB34L

22.0" x 15.88" x 19.25" (H x W x D)

Silent absorption minibar for hotel use, in gray finish with front lock

Highlights:

- Minimum maintenance with automatic defrost
- Slim width under 16" to fit narrow spaces
- Absorption technology ensures silent operation
- Perfect for hotel rooms and suites



Thin-line design	Our unique 16" wide models offer full capacity in a slim fit
Silent operation	Non-compressor technology for noiseless performance
Front lock	Keyed lock for a secure interior
Automatic defrost operation	Reduced user maintenance with auto defrost system
Adjustable metal shelf	Rearrange your minibar space to accommodate all shapes and sizes or remove shelves for a simple clean-up
Door storage	Store large bottles right on the door for easy access
100% CFC free	Environmentally friendly design without ozone-damaging chemicals

MB34L Specifications:

Height	22.0"
Width	15.88"
Depth	19.25"
Ext Depth with Handle	17.88"
Interior Height 1	18.0"
Interior Width 1	13.13"
Interior Depth 1	9.75"
Shipping Weight	60.0 lbs.
US Electrical Safety	UL
Reversible	Yes
Door Swing	RHD
Shelf Quantity	2
Adjustable Shelf	true
Shelf Type	Chrome
Full Door Shelf Quantity	2
Defrost Type	Automatic
Height to Hinge Cap	22.13"
Depth with door at 90°	32.0"
Thermostat Type	Dial
Parts/Labor Warranty	1 Year

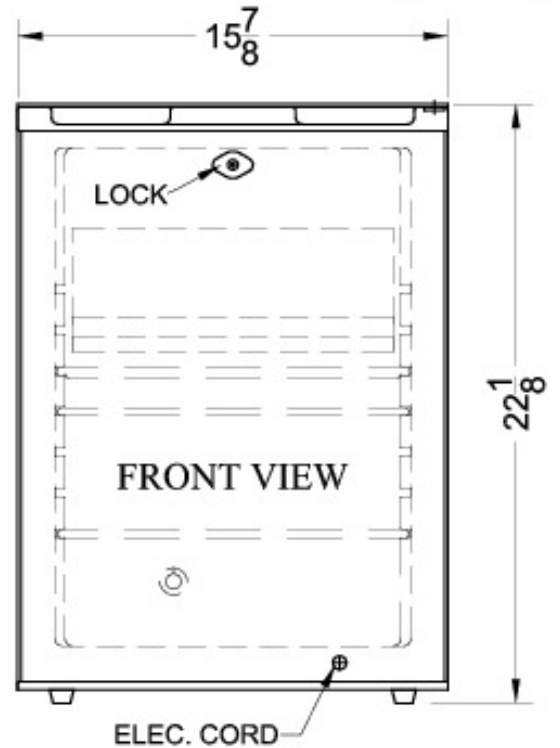
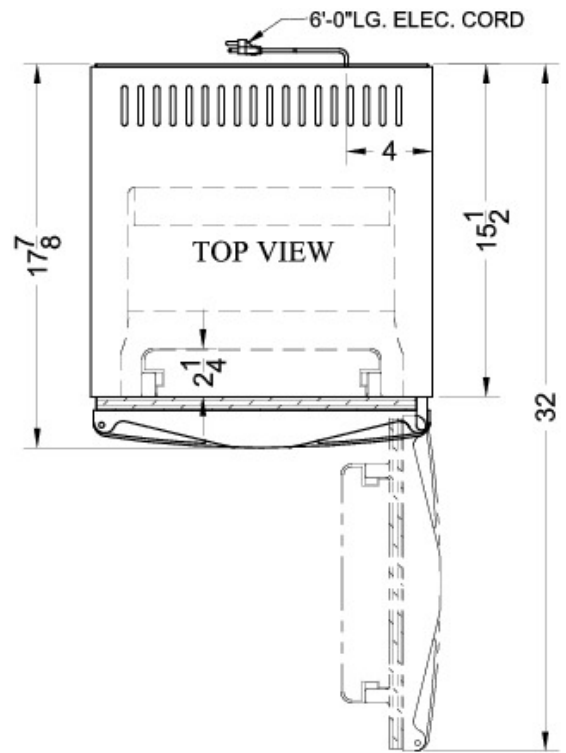

Summit Appliance Division, Felix Storch, Inc.
 770 Garrison Ave • Bronx, NY 10474
 Phone: 718-893-3900 • Fax: 718-842-3093
 Email: info@summitappliance.com